

DEBIE – FIRST STANDARD IN-SITU DEBRIS MONITORING INSTRUMENT

J. Kuitunen⁽¹⁾, G. Drolshagen⁽²⁾, J.A.M. McDonnell⁽³⁾, H. Svedhem⁽⁴⁾, M. Leese⁽⁵⁾, H. Mannermaa⁽⁶⁾,
M. Kaipiainen⁽⁷⁾, V. Sipinen⁽⁸⁾

⁽¹⁾ *Patria Finavitec Oy Systems, Naulakatu 3, 33100 Tampere, Finland, Email: juha.kuitunen@patria.fi*

⁽²⁾ *ESA/ESTEC, PB 299, NL-2200AG Noordwijk, The Netherlands, Email: Gerhard.Drolshagen@esa.int*

⁽³⁾ *The Open University, Walton Hall, Milton Keynes, MK7 6AA, United Kingdom, Email:
J.A.M.Mcdonnell@open.ac.uk*

⁽⁴⁾ *ESA/ESTEC, PB 299, NL-2200AG Noordwijk, The Netherlands, Email: Hakan.Svedhem@esa.int*

⁽⁵⁾ *The Open University, Walton Hall, Milton Keynes, MK7 6AA, United Kingdom, Email: M.R.Leese@open.ac.uk*

⁽⁶⁾ *Patria Finavitec Oy Systems, Naulakatu 3, 33100 Tampere, Finland, Email: hannu.mannermaa@patria.fi*

⁽⁷⁾ *Metorex International Oy, PB 85, 02631 Espoo, Finland, Email: Matti.Kaipiainen@metorex.fi*

⁽⁸⁾ *Space Systems Finland Oy, Kappelitie 6, 02200 Espoo, Finland, Email: ville.sipinen@ssf.fi*

ABSTRACT/RESUME

Objects larger than a few centimetres can be tracked with radar or with optical telescopes. The population of smaller particles can only be investigated by the analysis of retrieved spacecraft and passive detectors or by in-situ monitors in orbit. Patria Finavitec together with UniSpace Kent have developed the DEBIE (DEBris In-orbit Evaluator) instrument to determine the parameters of sub-millimetre sized space debris and micrometeoroids in-situ by their impact with a detecting surface. The main goal has been to develop an economical and low-resource instrument, easy to integrate into any spacecraft, while providing reliable real-time data for space debris modelling.

1. BACKGROUND

Many different detection methods of hypervelocity impacts are known [1] and several impact detectors have already been developed and flown in space. They have been usually built as one-off prototypes for certain scientific missions. Before the development of the DEBIE instrument was started a standard type of detector, which can easily be adapted to different spacecraft was not yet available.

The DEBIE instrument is based on a prototype sensor unit developed by UniSpace Kent (USK) at Canterbury, England. The idea is to combine several different detectors to improve the reliability of the measurement. Patria Finavitec has been the prime contractor for ESA and designed the electronics in developing an industrial version of the instrument. Subcontractors include Metorex International (mechanical design and manufacturing of the Sensor Unit) and Space Systems Finland (flight software). UniSpace Kent has provided scientific support.

2. DEBIE REQUIREMENTS

In order to develop a standard space debris monitoring instrument the following fundamental requirements were identified:

- Measure mass and velocity of sub-millimetre sized particles
- Detector based on an existing prototype concept developed by UniSpace of Kent
- Combination of impact ionisation, momentum and foil penetration detection
- Standard instrument, which can be flown on different spacecraft and missions with little or no modifications
- Low mass and power consumption
- Minimise recurrent costs of flight units
- Optimise the effort for manufacturing, assembly and testing of subsequent flight units
- Central processing unit and up to four separate sensor units
- As far as possible autonomous operation, controlled from the ground by telecommand and telemetry via the spacecraft
- On-board classification of events

One of the challenges, which was identified is the fact that the Sensor Unit can directly face the Sun. This can cause stress to the electronics and affect the accuracy of the measurements.

3. CONSTRUCTION

The DEBIE instrument consists of a Data Processing Unit (DPU) and up to four Sensor Units (SU). The Sensor Units can be placed on different sides of the spacecraft to detect particle impacts from different directions as shown in Fig.1. The data from each particle impact is classified and logged by the Data

Processing Unit for further telemetry transmission to the ground station via the spacecraft's on-board data handling.

Each Sensor Unit implements a basic impact detector measuring the plasma generated by the impacts, the momentum and penetration of a thin aluminium foil. The detection area of the Sensor Unit is 10 x 10 cm.

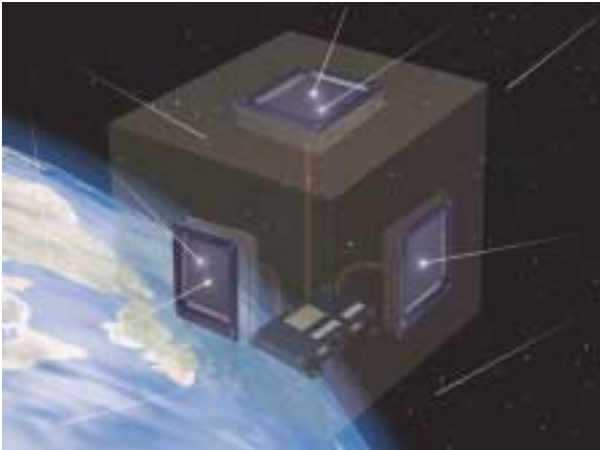

Fig. 1. DEBIE DPU and Three Sensor Units

Two plasma detectors are placed in front of a thin aluminium foil, one for electrons and one for positive ions. They measure the plasma generated by the particle impacts on the foil. Two piezoelectric transducers are coupled mechanically to the foil and measure the momentum of the impact. Particles with sufficient energy to penetrate the foil are detected by the plasma detector (electrons) placed behind the foil. The particle velocity and mass can be calculated from the measured parameters with the aid of predefined calibration data. The instrument can detect particles with a mass of 10^{-15} g or larger (depending on the impact velocity).

The coincidence measurement in different channels provides detailed information on impact parameters and allows better distinction between real impacts and noise events. Previous experience with less sophisticated in-situ detectors has shown that such a capability is very important.

4. FUNCTIONAL DESCRIPTION

Up to four Sensor Units can be interfaced to the DPU at the same time. Any combination of the Sensor Units on-board can be used for particle detection. This improves the operational flexibility of the instrument and allows the user to save power by switching off Sensor Units separately. In the following a short overview of the DEBIE instrument is given. More details can be found in [2].

There are three functions running in parallel to perform the tasks required from DEBIE: Acquisition of impact data, Health Monitoring and Telemetry/Telecommand functions.

4.1 Acquisition Function

The Acquisition function produces the scientific data. It detects and counts the incoming particles from each Sensor Unit separately. The SU temperature and time tag is extracted for each detected particle impact. The measurement data along with the SU temperature and time tag is stored into a science data buffer for later telemetry transfer to the spacecraft.

The events (real particle impacts or noise generated events) are classified into 10 different classes according to signal amplitudes and co-incidence of signals from different detector channels. A quality number between 0 and 255 is also calculated for each event. The quality number is used to discard poor events in favour of good ones in case the science data buffer is already full.

4.2 Health Monitoring Function

The Health Monitoring function monitors continuously the state of the DEBIE instrument. It produces housekeeping telemetry data by measuring periodically supply voltages and internal temperatures of the instrument. It runs self tests and maintains various error status registers and failure counters for diagnostic purposes. It is also responsible for protective actions such as switching off a Sensor Unit in case a short circuit on secondary power lines or over heating of the Sensor Unit is detected.

4.3 Telemetry/Telecommand Function

The Telemetry/Telecommand (TM/TC) function receives and executes the telecommands sent by the spacecraft and provides all science and housekeeping data to the spacecraft via telemetry.

Each telecommand is verified before execution. The last received telecommand and its time tag is included in the telemetry. The Error Status register indicates whether the command was accepted or rejected and the reason for rejection.

5. ELECTRICAL ARCHITECTURE

The block diagram of the instrument is shown in Fig. 2. To keep the costs and mass/volume at minimum the instrument is not redundant. However a certain degree of redundancy is achieved by using several Sensor Units, which can be independently switched on/off.

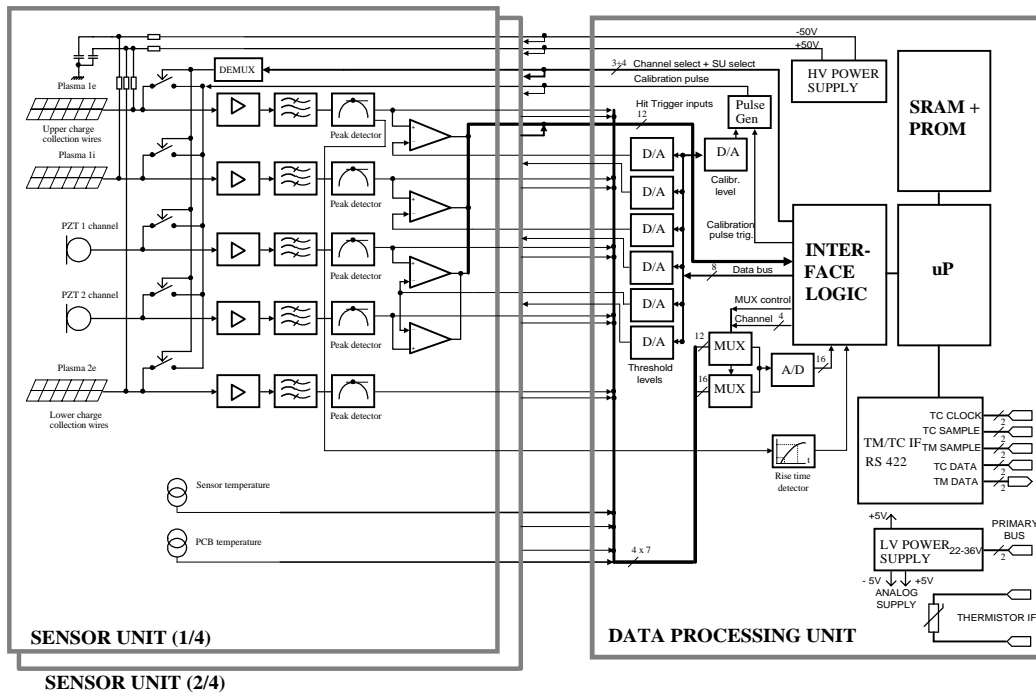

Fig. 2. Block Diagram of DEBIE

5.1 Sensor Unit

The Sensor Unit provides proximity electronics for three plasma detector channels, two piezoelectric transducers (PZT) and two temperature sensors. The charge collection wires of the plasma channels are biased to ± 50 V. The analogue chains of the plasma and PZT channels are in principal similar to each other. A high gain charge amplifier is used to provide most of the sensitivity. It is followed by a filtering/low gain stage. The main difference between the channels is the band width characteristics, which is optimised for each channel. Finally the amplified and filtered signal is sampled by a peak detector.

Three independent triggering signals are generated by voltage comparators to indicate a detected particle impact to the DPU. The reference level is adjustable separately for all three triggers.

One of the temperature sensors is placed close to the piezoelectric transducer. Thus the measured temperature can be used to compensate the temperature coefficient of the PZT. The Sensor Unit can face towards the Sun or cold space and therefore the temperature variation of the foil and PZTs can be quite large. The second temperature sensor is used to measure the temperature of the electronics.

For self test purposes it is possible to check the response of each sensor channel to a calibration pulse. This can also be done during flight with a single telecommand.

5.2 Data Processing Unit

The DPU is implemented with a radiation tolerant 8-bit microcontroller 80C32. It provides the necessary data and power interfaces for the spacecraft and four Sensor Units.

The nominal primary power interface to the spacecraft is +28 V. The TM/TC interface is a synchronous serial interface according to the ESA TTC-B-01 standard with RS-422 signalling levels. An asynchronous serial interface is optionally available.

The DPU provides adjustable reference levels to each Sensor Unit separately for trigger thresholds. An interrupt will be generated to the microcontroller when a particle impact is detected by one of the Sensor Units. The peak detector outputs of the triggering Sensor Unit are sampled by the Analogue-to-Digital converter. Also the relative timing of the triggering signals (between plasma and PZT channels) is measured.

6. FLIGHT SOFTWARE

The DEBIE DPU flight software is written in the C language with some assembler subroutines and uses the Keil RTX51 real-time kernel [3].

To fulfil the functional requirements the flight software provides the following concurrent tasks [4]:

- Telecommand Execution Task for executing ground commands, supported by TC and TM interrupt services.
- Health Monitoring Task for performing housekeeping measurements and monitoring the health of the instrument.
- Hit Trigger Interrupt Service Task for measuring the peak detector outputs of the triggering Sensor Unit. This task is attached directly to the hit trigger interrupt.
- Acquisition Task for performing other data acquisitions for the particle hit event, classification of the event and storing of the event data.

7. MECHANICAL DESIGN

The goal of the mechanical design was to keep the mass budget low while maintaining adequate safety margins. Surface mounted devices have been used as far as possible to keep the size of printed circuit boards reasonably small.

The structure of the Sensor Unit is unique and is therefore treated here in more detail. A cross section of the 3-D Finite Element -model (FE-model) is shown in Fig. 3.

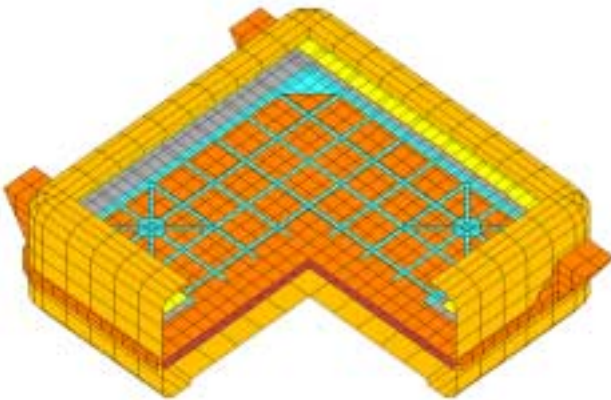

Fig.3. 3-D FE-model of the Sensor Unit

Only the body structure of the Sensor Unit is machined to provide the required stiffness. The body separates the electronics from the plasma and foil assemblies and protects the electronics from the environment. The 1.0

mm thick upper and bottom covers are deep drawn into their final shape. The sensor aperture (10 cm x 10 cm) is on the upper cover.

In the topmost position is the grounded wire grid assembly, which provides shielding against fluctuating plasma and increases the efficiency of the plasma sensors (see Fig. 4.). Below the grounded grid is the plasma stage and below it the aluminium foil glued on a supporting grid. The PZTs are glued on the two corners of the supporting grid (in the centre of diagonal bars). Below the foil is the lower plasma stage to detect penetrating particles.

The steel wires of each wire grid (not shown in Fig. 3.) are stretched between two spring comb plates to provide elasticity under mechanical vibration.

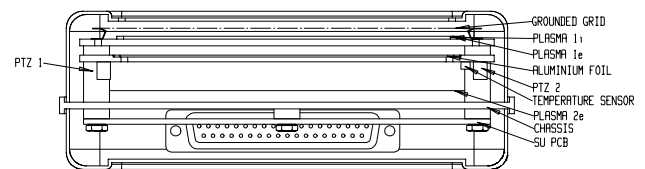

Fig.4. Side View of the Sensor Unit

8. QUALIFICATION TESTS

8.1 Prototype Model

The model philosophy was to first design and build a prototype to evaluate the performance of the instrument and to verify that especially the Sensor Unit will withstand the environmental stresses. The following environmental tests were performed on the SU Prototype:

- Acoustic test
- Random and sine vibration
- Shock test
- Thermal cycling.

The only serious difficulty was encountered during the random vibration test of the SU Prototype. The thin aluminium foil was torn from the side of the both PZTs. It was deduced that the mass of the PZT caused a local vibration to the foil with a too large amplitude. The design of the supporting aluminium grid was modified by adding diagonal bars to damp the local vibration around the PZTs. After that the random vibration test was repeated successfully.

8.2 Proto Flight Model

The qualification of the Proto Flight Model (PFM) included the following tests:

- Functional and performance tests
- EMC tests
- Random and sine vibration tests
- Shock test
- Thermal cycling

A few non-conformances were found during the EMC tests. The limits for conducted emissions on the primary power lines were slightly exceeded on three spot frequencies. The radiated emissions were well below limits in all frequency bands.

However the main concern was the susceptibility to external interference as expected due to the open structure of the Sensor Unit. The sensitivity of the plasma channels was reduced under interference whereas the PZT channels were not affected. The maximum interference to radiated electric field occurs at 1.43 GHz where the aperture of the Sensor Unit is $\frac{1}{2} \lambda$ (105 mm). Therefore attention should be paid to the installation of the Sensor Unit so that it is not exposed directly to any RF field (spacecraft down link, etc.).

Some susceptibility was also detected to AC-magnetic field and conducted ground currents on the secondary grounding line resulting in a reduced sensitivity of plasma channels. The interference is coupled into the plasma channels through stray capacitances between the structure and plasma wire assemblies. However it is not possible to fully eliminate these stray capacitances due to the mechanical structure of the Sensor Unit.

In other respects the performance and the environmental tests of the PFM were successful.

9. CALIBRATION TESTS

The most important test for DEBIE was the calibration test at the 2MV Van de Graaff accelerator with hypervelocity impacts. This test was first performed on the SU Prototype at the University of Kent at Canterbury (UKC) and then on two SU PFMs at the Max Planck Institute für Kernphysik (MPI-K) in Heidelberg.

The accelerator was used to impact iron particles onto the DEBIE Sensor Units. The calibration included electron and ion collection efficiency at the upper plasma channels, penetration events with electron collection at the lower plasma channel and momentum

signals from both PZT channels [5]. Moreover the relative timing of the signals was studied [6].

9.1 Sensor Unit Prototype

A total number of 250 events were recorded for the Prototype during two separate calibration sessions. The velocity range was from 0.1 km/s to 70 km/s.

The first calibration test revealed a deficiency in the plasma stage properties, which caused attenuation to the ion channel signal. The structure of the plasma stage was modified and the calibration test was repeated successfully.

The calibration tests showed that the upper plasma channels and PZT channels were performing as expected. No penetrations were detected with the lower plasma channel. This was caused by the fact that the UKC accelerator could not produce particles with a momentum high enough to penetrate the foil.

Moreover different beam angles were studied. The sensitivity of the plasma channel was not greatly affected by the incident angle of the impact. The sensitivity of the PZT channels was reduced by a factor of 0.7 for 40° angles compared to a perpendicular impact.

Also a comprehensive sensitivity mapping of the PZT channels was conducted over the foil surface with a special piezoelectric stimulator test facility developed by UniSpace Kent.

9.2 Sensor Unit Proto Flight Models

A total number of 530 events were recorded during the PFM calibration. The velocity range achieved with the MPI-K accelerator was from 1 km/s to 32 km/s.

For both Sensor Units the results of the PZT channels were consistent both with each other and with the SU Prototype as well as with the USK prototype results.

Also the results of the upper plasma stages compare well between the two PFMs. However the collected charge per unit mass was lower than for the Prototype. The further tests of the DEBIE-2 (second flight model) Sensor Units again at the UKC accelerator were consistent with the Prototype results. Therefore it is now assumed that the lower yield of the PFM Sensor Units was caused by the different accelerator facility or dust properties. This is still under investigation. A typical yield of plasma per unit particle mass as a function of particle velocity is plotted in Fig. 5.

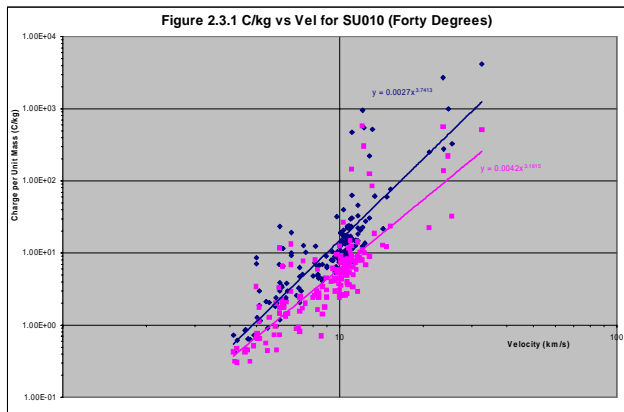

Fig. 5. Electron and Ion Channel Yield

For both PFM Sensor Units also several penetration events were recorded. These impacts produced good signals on all five detector channels.

10. DEBIE SPECIFICATIONS

- Dimensions (X x Y x Z)
 - SU: 157 mm x 135 mm x 47 mm
 - DPU: 156 mm x 136 mm x 42.5 mm
- Mass
 - SU: 560 g
 - DPU: 740 g
 - Total with 4 SUs and harness: 4 kg
- Power consumption with four SUs: less than 4 W
- Operational temperature range: -30 °C...+55 °C
- Interfaces to spacecraft
 - Primary Power Interface: +28 V (+22 V...+36 V)
 - TM/TC Interface: synchronous or asynchronous serial interface
- Detection area: 100 cm² / SU
- Five detector channels:
 - One electron and one ion detector in front of the foil
 - Two piezoelectric transducers
 - One electron detector behind the foil detecting the penetrations
- Sensitivity (velocity dependent)
 - Plasma Channels: better than 10⁻¹⁵ g
 - PZT Channels: better than 10⁻¹⁴ g
- Foil thickness: 6 μm
- On-board classification of events
- Science data storage: 1260 events

11. FLIGHT OPPORTUNITIES

The DEBIE PFM with two Sensor Units will fly onboard the PROBA (PProject for On Board Autonomy)

satellite to be launched in 2001 to a polar orbit. The PROBA satellite is an ESA mission of technology demonstration for on-board autonomy. The next flight model DEBIE-2 will be placed on the International Space Station in 2004 (TBC).

It is envisaged to place a third flight model DEBIE-3 into a high altitude or interplanetary orbit. However the possibilities are still under investigation and the actual spacecraft has not yet been identified.

12. FURTHER DEVELOPMENT

The DEBIE instrument is an off-the-shelf product and can be placed on virtually any spacecraft. However to provide a more versatile product family the detector area could be further increased to get more impacts. On the other hand a very compact instrument could be designed especially for small missions by integrating the DPU and SU together.

13. CONCLUSION

The goal of the project was to design and manufacture a low resource, standard space debris monitoring instrument. This goal was successfully achieved.

The DEBIE instrument gives us a powerful tool to increase our knowledge about the debris environment around the Earth and in deep space. To get the most benefit from the DEBIE it should be placed on many different spacecraft and different orbits.

14. REFERENCES

1. J.A.M. McDonnell, P. Ratcliff, H. Jolly, H. Shaw and M. Wright, *DEBris In-Orbit Evaluator*, Unit for Space Sciences and Astrophysics, University of Kent at Canterbury, 1996.
2. M. Muukki and J. Kuitunen, *DEBIE User Manual*, Patria Finavitec Oy Systems, DEB-FIN-MA-001, 6.9.2000.
3. H. Paloheimo, *Evaluation of Debris in Orbit*, Master's Thesis, Helsinki University of Technology, 2000.
4. N. Holsti and T. Långbacka, *Using a Worst-Case Execution for Real Time Verification of the DEBIE Software*, DASIA 2000, ESA SP-457, 2000.
5. M.R. Leese and J.A.M. McDonnell, *DEBIE PFM Sensors Calibration Report*, UniSpace Kent, DEBIE-UKC-RP-001, 28.2.2000.
6. H. Mannermaa, *DEBIE PFM Calibration Test Report*, Patria Finavitec Oy Systems, DEB-FIN-TR-029, 17.4.2000.